

RESOLUTION NO. 2349

A RESOLUTION OF THE CITY OF WILSONVILLE REVISING A "LOCAL SHARE" PROJECT LIST TO BE FUNDED WITH A PORTION OF METRO'S NOVEMBER 2006 NATURAL AREAS BOND MEASURE

WHEREAS, Metro received voter approval for a regional Natural Areas Bond Measure in November of 2006 to continue to purchase significant natural areas, and fund related capital improvement projects, similar to the Greenspaces Bond passed in 1995; and

WHEREAS, the total general obligation bond amount was \$227 million dollars, with \$44 million passed down to local park providers as part of the Local Legacy Program (aka "Local Share") to implement projects at the local level; and

WHEREAS, the City of Wilsonville, as a local park provider received \$806,521 from the bond measure passed by the regional voters; and

WHEREAS, Metro requested each of the local park providers to support the Local Share per capita allocation methodology, which the City Council adopted in Resolution No. 1968; and

WHEREAS, Metro requested that each of the local park providers establish a Local Share project list, which the City Council adopted in Resolution No. 1981; and

WHEREAS, the City of Wilsonville has adopted three significant Master Plans, the Parks and Recreation Master Plan, the Graham Oaks Natural Area Master Plan and the Memorial Park Trails Plan that contain priorities and cost estimates of projects that would be eligible for Local Share funding; and

WHEREAS, these Plans have been through substantial public process and represent community and City Council priorities; and

WHEREAS, without receiving an extension, the funding deadline for Local Share projects is March 31, 2013; and

WHEREAS, the Boeckman Creek Trail project, included in the Local Share project list, will not meet the Local Share funding deadline due to significant delays in starting the project; and

WHEREAS, Engelman Park, which was approved the Parks and Recreation Advisory Board on December 8, 2011 and the Development Review Board on February 27, 2012, is eligible for Local Share funding and will be designed and constructed in 2012; and

WHEREAS, the City of Wilsonville received a \$200,000 grant from Oregon Parks and Recreation Department to design and develop Engelman Park; however, additional funds are necessary to develop the park; and

WHEREAS, Metro staff has approved the reallocation of \$126,521 in funding from the Boeckman Creek Trail project to Engelman Park; and

WHEREAS, the City of Wilsonville is supportive of Metro's effort and is desirous to assist Metro in establishing a successful regional Greenspaces program.

NOW, THEREFORE, THE CITY OF WILSONVILLE RESOLVES AS FOLLOWS:

1. The City of Wilsonville revises the following Local Share project list:
 - **Implement projects in the Graham Oaks Natural Area (GONA) Master Plan:**
 - * Develop the CREST Environmental Center "gateway" to GONA with restrooms and associated amenities
 - * Trail head improvements and pathway construction
 - * Interpretive graphics, picnic and wildlife viewing areas
 - * Oregon white oak savanna and woodland restoration
 - **Implement projects in the Memorial Park Trails Plan:**
 - * Construct multi-use paths in Memorial Park
 - * Construct Willamette River overlook platforms (3) and associated amenities such as seating and signage
 - **Implement Engelman Park in the Montebello Neighborhood**
 - * Construct trail improvements
 - * Provide play and picnic areas and associated amenities
2. This resolution becomes effective upon the date of adoption.

ADOPTED by the Wilsonville City Council at a regular meeting thereof this 19th day of March 2012, and filed with the Wilsonville City Recorder this same date.

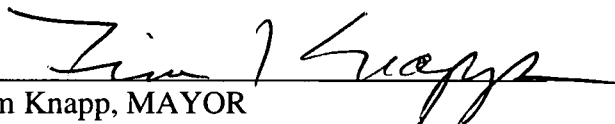

Tim Knapp, MAYOR

ATTEST:

Sandra C. King, MMC, City Recorder

SUMMARY OF VOTES:

Mayor Knapp	<u>Yes</u>
Councilor President Núñez	<u>Yes</u>
Councilor Hurst	<u>Yes</u>
Councilor Goddard	<u>Yes</u>
Councilor Starr	<u>Yes</u>

Engelman Park in the Montebello Neighborhood

Background:

The City of Wilsonville's Parks and Recreation Master Plan (2007) identified the need for a park in the Montebello neighborhood as one of its top priorities. This neighborhood is home to numerous low-income housing units and higher density developments and is underserved with park space and recreation opportunities. In September 2006 the City acquired a .68 acre parcel that is contiguous to a City-owned .21 acre beautification area in this neighborhood. The City's intent is to redevelop the combined parcels into a neighborhood park.

In March 2011, staff presented a conceptual plan to the Parks and Recreation Advisory Board in advance of reapplying for an Oregon Parks and Recreation grant after being denied the grant the previous year. To increase the likelihood of receiving grant funding, staff hired a consultant to develop a more refined, concept plan for the park.

In addition, staff implemented an outreach plan to receive input from the Montebello neighborhood. A postcard was mailed to residents of the neighborhood in early December 2010, which included an invitation to an open house in January 2011. A survey was also posted on the City's website. The overall feedback from the public was positive and a fair amount of input was received on the desired features of the park. This input was incorporated into the presentation/application to the Oregon Parks and Recreation Grant Advisory Committee.

In July 2011, the Oregon Parks and Recreation Commission granted the City \$200,000 for the development of a neighborhood park that includes trails, native plantings, natural play area, benches, picnic shelter, interpretive signage, and lawn area. Staff formed a multi-departmental internal design team and selected GreenWorks to complete the final design and construction documents, and assist staff with soliciting bids for the construction of the park. A grand opening for the park is anticipated in the summer of 2012.

Renaming the Park:

Linda Engelman, a long-time resident whose family history has been tied to the Montebello Park property since the early 1900s, has been a part of the public outreach process and has met with staff to discuss the family history for the interpretive sign that will be placed in the newly developed park. The City's internal design team met to discuss the option of changing the name of the park to better represent its history and connection to the community. We discussed the theme of the park with the focus on the urban forest and determined that the role of the Engelman family in planting the trees that currently exist, including the Engelmann Spruce, make the park what it is today. The Parks and Recreation Advisory Board approved the renaming of the park at their meeting on December 8, 2011.

Final Site Plan and Public Outreach:

Input from the public outreach efforts along with several meetings with the internal design team and GreenWorks helped shape the process from the draft concept plans to the final site design.

Working with GreenWorks and the internal design team, staff has developed a final site plan, which was based on the conceptual design for Engleman Park. The park includes opportunities for play, walking, picnicking, relaxation, and contemplation of nature. Accessibility, safety and low maintenance needs were all important considerations in the design.



DRAWING INDEX

SHEET DESCRIPTION	SHEET NUMBER
DEMOLITION AND TREE PROTECTION PLAN	L1.0
MATERIALS PLAN	L2.0
GRADING PLAN	L3.0
IRRIGATION PLAN	NOT INCLUDED
PLANTING PLAN	L5.0
SITE DETAILS	L6.0
SITE DETAILS	L6.1
SITE DETAILS	L6.2
IRRIGATION DETAILS	L6.3

ENGELMAN PARK

GREENWORKS, PC.







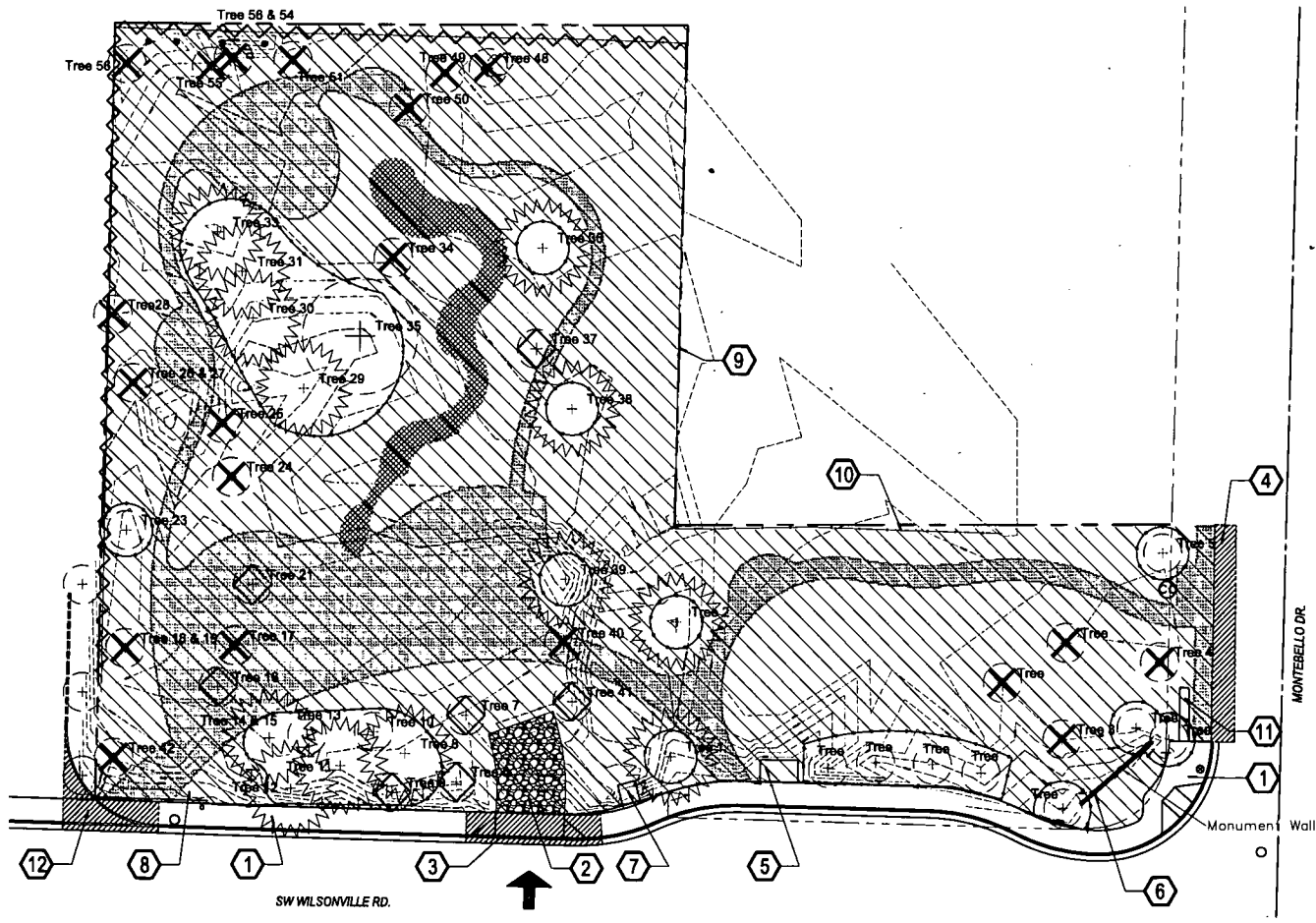



LANDSCAPE ARCHITECTURE
ENVIRONMENTAL DESIGN
24 NW 2ND AVENUE, SUITE 100
PORTLAND, OREGON 97209
P: (503) 222-6612

CITY OF WILSONVILLE
28799 SW TOWN CENTER LOOPE
WILSONVILLE, OR 97070

LAND USE PERMIT SET
FEBRUARY 1, 2012

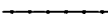

DEMOLITION LEGEND

-  CONSTRUCTION ACCESS
-  EXISTING EVERGREEN TREE TO BE PROTECTED IN PLACE TO REMAIN UNDISTURBED - SEE TREE PROTECTION SPECIFICATIONS
-  EXISTING DECIDUOUS TREE TO BE PROTECTED IN PLACE TO REMAIN UNDISTURBED - SEE TREE PROTECTION SPECIFICATIONS
-  EXISTING TREE TO BE REMOVED
-  TREES TO BE FELLED AND REUSED IN LANDSCAPE
-  CLEAR AND GRUB
-  EXCAVATE FOR SIDEWALKS AND PAVEMENT (SEE GRADING PLAN AND DETAILS FOR DEPTHS)
-  EXCAVATE FOR DRY CREEK BED (SEE GRADING PLAN AND DETAILS FOR DEPTHS)
-  PAVEMENT REMOVAL
-  TREE PROTECTION FENCING
-  SITE PROPERTY LINE
-  EXISTING FENCE TO BE REMOVED

NOTES

1. ALL TREES, EXCEPT THOSE DESIGNATED ON THIS DRAWING TO BE REMOVED SHALL BE PROTECTED IN PLACE - SEE DESCRIPTIONS.
2. SEE ARBORIST REPORT BY OTHERS.
3. PLACE TREE PROTECTION FENCING PRIOR TO ANY SITE WORKER DEMOLITION AT THE CONCLUSION OF ALL OTHER CONSTRUCTION ACTIVITIES.
4. STOCKPILE FELLED TREES ON SITE TO BE REUSED IN LANDSCAPE - LIMBS AND BRANCHES TO BE CLIPPED AND STOCKPILED FOR PLANTING AREA.
5. TREES NOT SELECTED FOR REUSE SHALL BE REMOVED AND DISPOSED OFF-SITE.

KEY NOTES

- | | |
|--|---|
|  EXISTING SIDEWALK TO REMAIN - PRESERVE AND PROTECT |  EXISTING UTILITY TRANSFORMER TO REMAIN - PRESERVE AND PROTECT |
|  CONSTRUCTION ENTRANCE PER CITY OF WILSONVILLE STANDARDS |  EXISTING UTILITY METERS TO REMAIN - PRESERVE AND PROTECT |
|  EXISTING DRIVEWAY - SAWCUT AND REMOVE CONCRETE SIDEWALK AND CURB |  EXISTING METAL FENCE TO REMAIN |
|  SAWCUT AND REMOVE EXISTING AC FOR NEW CURB AND GUTTER |  EXISTING WOOD FENCE TO REMAIN |
|  EXISTING CONCRETE PAD AT BUS STOP TO REMAIN - PRESERVE AND PROTECT |  EXISTING UTILITY BOX TO REMAIN - PRESERVE AND PROTECT |
|  EXISTING MASONRY WALL - REMOVE WALL AND FOOTINGS |  SAWCUT AND REMOVE EXISTING CURB AND PAVEMENT FOR NEW ADA RAMP |



GreenWorks, P.C.
Landscape Architecture
Professional Service
14 4th Street, Suite 50
Portland, Oregon 97201
Phone: 503.251.7400 FAX: 503.251.7401
Email: info@greenworks.com



1 in. = 10' Horizontal



1 in. = 10' Vertical

project: **Engelman Park**

submit: **LAND USE SET**
sheet title: **DEMOLITION AND TREE PROTECTION PLAN**

Date: 02-01-12
Revisions:





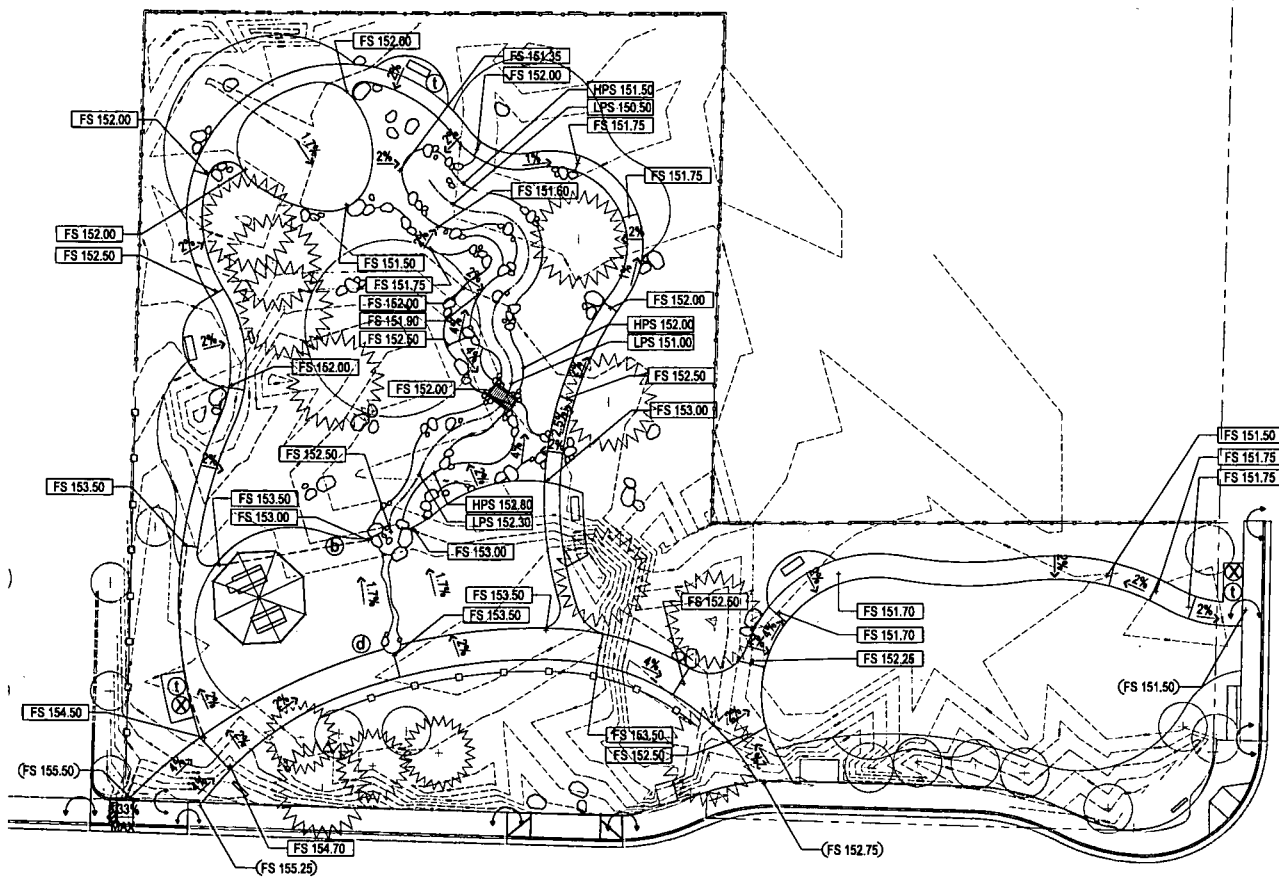

Drawn By: WS
Checked By: BJ
Job No. 110308
Approved: DE

L1.0
sheet no. X of X



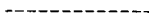

GRADING LEGEND

-  EXISTING EVERGREEN TREE
-  EXISTING DECIDUOUS TREE
-  EXISTING SPOT ELEVATION
-  PROPOSED SPOT ELEVATION
-  DIRECTION AND PERCENTAGE OF SLOPE
-  GRADE BREAK
-  MATCH ELEVATIONS
-  SITE PROPERTY LINE

ABBREVIATIONS

- TW TOP OF WALL
- BW BOTTOM OF WALL
- TC TOP OF CURB
- BC BOTTOM OF CURB
- HP HIGH POINT
- LP LOW POINT
- HPS HIGH POINT OF SWALE
- LPS LOW POINT OF SWALE
- FS FINISHED SURFACE
- FG FINISHED GRADE



GreenWorks, P.C.
Landscape Architecture
Environmental Studio
14 NW 3rd Avenue, Suite 300
Portland, Oregon 97209
Phone: 503.465.4222
Email: info@greenworks.com



1 of 10 sheets

project: **Engelman Park**

City of Wilsonville
Wilsonville, OR 97150

submittal: **LAND USE SET**

sheet title: **GRADING PLAN**

Date: **02-01-12**

Revisions:

Drawn By: **WS**
Checked By: **BJ**
Job No. **110308**
Approved: **DE**

L3.0

sheet no. X of X

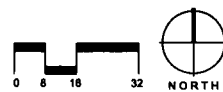

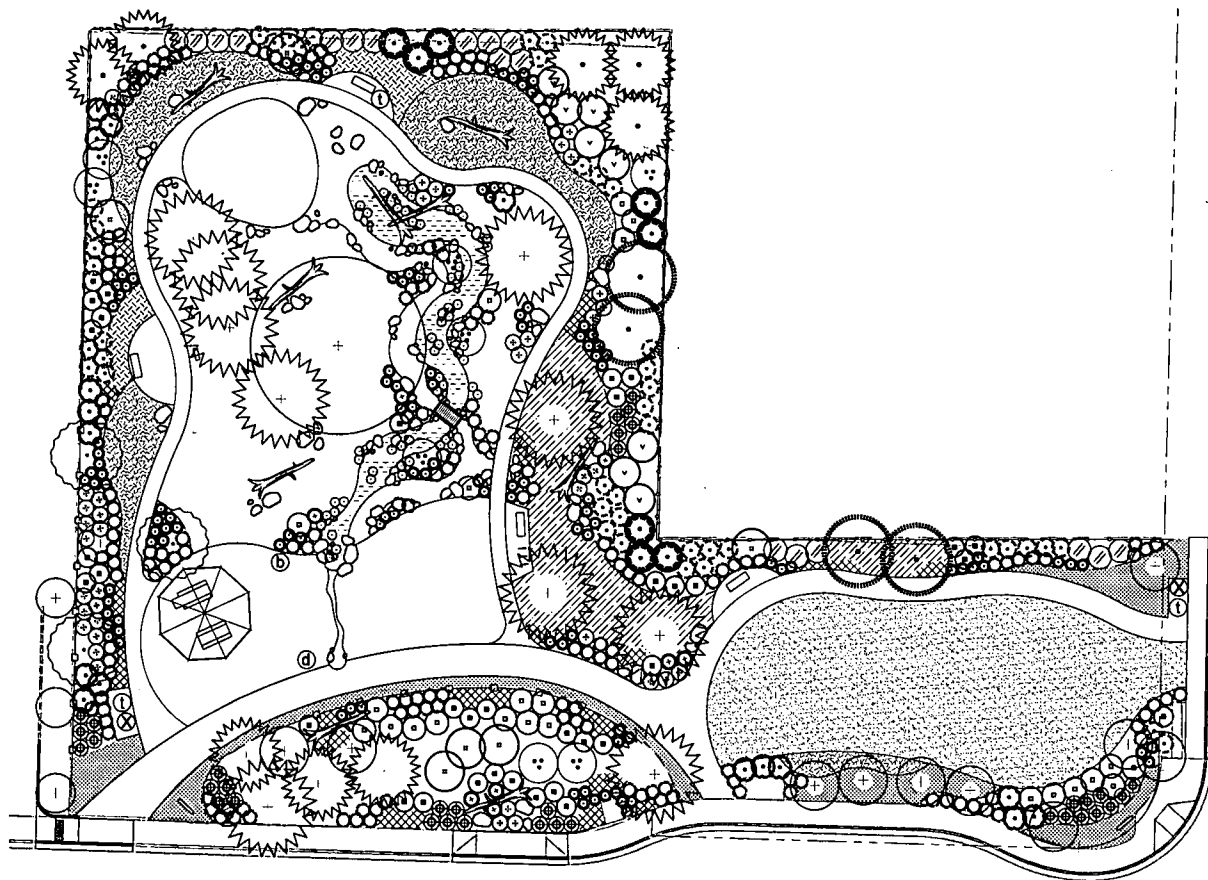

NOTES:

1. ALL NEW PLANTING AREAS SHALL BE IRRIGATED UTILIZING AN FULLY AUTOMATIC UNDERGROUND IRRIGATION SYSTEM. IRRIGATION SYSTEM SHALL INCORPORATE A SMART CONTROLLER, IN COMBINATION WITH LOW PRECIPITATION SPRAY HEADS AND DRIP DISTRIBUTION TUBING. IRRIGATION INTENT IS TO PROVIDE SUFFICIENT WATER TO ESTABLISH NEW PLANTINGS WITHIN THE FIRST TWO YEARS, AND THEN SLOWLY DECREASE WATERING, LIMITED TO DRY MONTHS, OR PERIODS OF DROUGHT THE FOLLOWING (3) YEARS.
2. CONTRACTOR SHALL PROVIDE TOPSOIL, SOIL AMENDMENTS AND MULCH AS SPECIFIED.
3. ALL PLANTS SHALL BE INSTALLED IN ACCORDANCE WITH THE DETAILS AND SPECIFICATIONS PROVIDED AS PART OF THE CONSTRUCTION DOCUMENT PACKAGE.
4. QUANTITIES ARE LISTED FOR THE CONTRACTOR'S CONVENIENCE ONLY. ALL COUNTS MUST BE VERIFIED BY THE CONTRACTOR. IN THE CASE OF A DISCREPANCY BETWEEN THE LEGEND AND THE PLAN, PLANTS INDICATED ON THE PLAN SHALL SUPERCEDE QUANTITIES LISTED IN THE LEGEND.
5. TREE REMOVAL AND PROTECTION SHALL BE PER ARBORIST RECOMMENDATION - SEE REPORT BY MORGAN HOLEN AND ASSOCIATES DATED 11-23-11.
6. LOGS FROM SITE TREE REMOVAL TO BE BURIED 1/3 TO 1/2 IN GROUND.
7. EXISTING TREE LOCATION / INFORMATION PROVIDED BY CITY OF WILSONVILLE.
8. LOGS FROM SITE TREE REMOVAL TO BE BURIED 1/3 TO 1/2 IN GROUND.
9. TREE REMOVAL AND PROTECTION SHALL BE PER ARBORIST RECOMMENDATION - SEE REPORT BY MORGAN HOLEN AND ASSOCIATES DATED 11-23-11.
10. EXISTING TREE LOCATION / INFORMATION PROVIDED BY CITY OF WILSONVILLE.

PLANTING LEGEND

TREES

- ① EXISTING DECIDUOUS TREES TO REMAIN UNDISTURBED
SEE DEMOLITION AND TREE PRESERVATION PLAN
- ② EXISTING CONIFER TREES TO REMAIN UNDISTURBED
SEE DEMOLITION AND TREE PRESERVATION PLAN
- ③ QTY: ACER CIRCINATUM
④ WINE MAPLE; 8'-10' BAB, SPACE AS SHOWN - MULTI STEM (3 STEM MIN.)
- ⑤ QTY: CORNUS MUTTALLI 'EDDIE'S WHITE WONDER'
⑥ PACIFIC DOGWOOD; 7' CAL. BAB
- ⑦ QTY: OSMERIA CERASIFORMIS
⑧ INDIAN PLUM; 6'-8' 5 GAL. CONT.
- ⑨ QTY: PSEUDOTSUGA MENZIESII
⑩ DOUGLAS FIR; 8'-10' BAB, SPACE AS SHOWN
- ⑪ QTY: RHAMNUS PURSHIANA
⑫ CASCARA; 1.5' CAL. CONT., SPACE AS SHOWN
- ⑬ QTY: THUJA PLICATA 'FASTIGIATA'
⑭ HOGAN CEDAR; 8'-7' BAB, SPACE AS SHOWN

SHRUBS/GRASSES/PERRENIALS/GROUNDCOVER

- ⑮ QTY: CEANOTHUS THYRSIFLORUS
⑯ BLUE BLOSSOM; 5 GAL. CONT., SPACE AS SHOWN
- ⑰ QTY: CORNUS SERICEA
⑱ RED TWIG DOGWOOD; 5 GAL. CONT., SPACE AS SHOWN
- ⑲ QTY: CORNUS SERICEA 'FLAVIRAMEA'
⑳ YELLOW TWIG DOGWOOD; 5 GAL. CONT., SPACE AS SHOWN
- ㉑ QTY: ALCOUS PATENS
㉒ CALIFORNIA GREY RUSH; 1 GAL. CONT., SPACE AS SHOWN
- ㉓ QTY: HOLODISCUS DISCOLOR
㉔ OCEANSPRAY; 5 GAL. CONT., SPACE AS SHOWN
- ㉕ QTY: MAHONIA AQUIFOLIUM
㉖ OREGON GRAPE; 5 GAL. CONT., SPACE AS SHOWN
- ㉗ QTY: MAHONIA NERVOSA
㉘ OREGON GRAPE; 5 GAL. CONT., SPACE AS SHOWN
- ㉙ QTY: POLYSTICHUM MUNITUM
㉚ SWORD FERN; 2 GAL. CONT., SPACE AS SHOWN
- ㉛ QTY: RIBES SANGUINEUM
㉜ RED FLOWERING CURRANT; 5 GAL. CONT., SPACE AS SHOWN
- ㉝ QTY: SPIRAEA DOUGLASSII
㉞ DOUGLAS SPIRAEA; 5 GAL. CONT., SPACE AS SHOWN
- ㉟ QTY: VACCINIUM OVATUM
㊱ EVERGREEN HUCKLEBERRY; 5 GAL. CONT., SPACE AS SHOWN
- ㊲ QTY: WOODWARDIA FIMBRIATA
㊳ GIANT CHAIN FERN; 5 GAL. CONT., SPACE AS SHOWN

- ① FRAGARIA CHILOENSIS
② BEACH STRAWBERRY; 1 GAL. CONT., 12" O.C.
- ③ GAULTHERIA SHALLON
④ SALAL; 1 GAL. CONT., 12" O.C.
- ⑤ DICENTRA FORMOSA
⑥ PACIFIC BLEEDING HEART; 1 GAL. CONT., 16" O.C.
- ⑦ MAHONIA REPENS
⑧ CREEPING MAHONIA; 1 GAL. CONT., 16" O.C.
- ⑨ SEEDED LAWN
- ⑩ DEMONSTRATION PLANTING AREAS
PLANTS TO BE FURNISHED AND INSTALLED BY OWNER
- ⑪ DRY CREEK BED

BOULDER: 18" - 36" ROUND FIELDSTONE

NURSE LOG - SELECTED FROM ON-SITE TREE REMOVAL



GreenWorks, P.C.
Landscape Architecture
Environmental Design
24 NW 3rd Avenue, Suite 200
Portland, Oregon 97209
Phone: 503.253.7400/503.253.2350
Email: info@greenworksusa.com



1 of 9 sheets

Project: **Engelman Park**

City of Wilsonville
315 SW 10th Street
Wilsonville, OR 97150

Submitted: LAND USE SET

sheet title: **PLANTING PLAN**

Date: 02-01-12
Revision:

Drawn By: WS
Checked By: BJ
Job No. 110308
Approved: DE

L5.0

sheet no. X of X

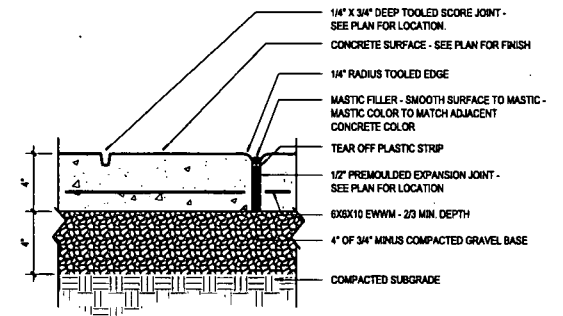
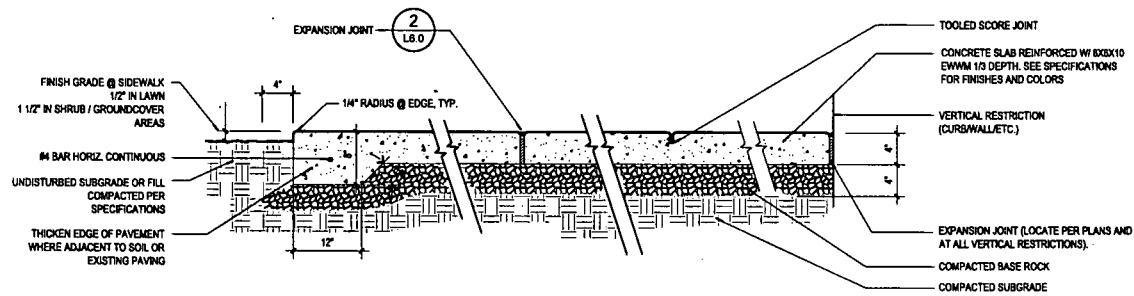

1 CONCRETE PAVING SECTION

2 EXPANSION & SCORE JOINT SECTION

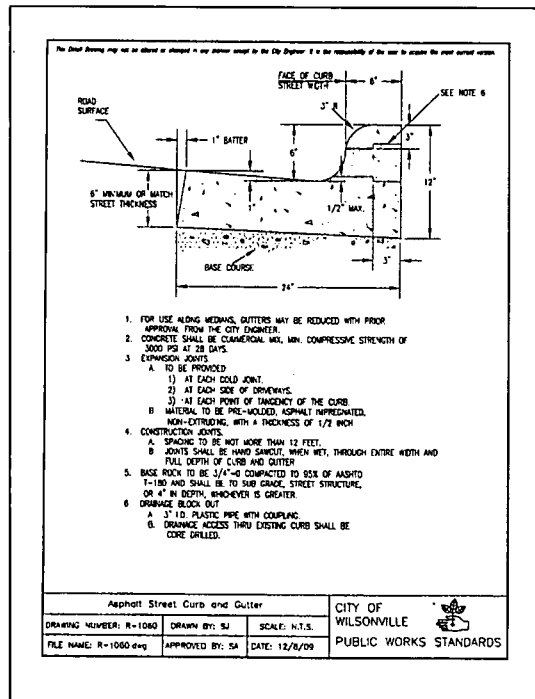

3 ASPHALT STREET CURB AND GUTTER SECTION

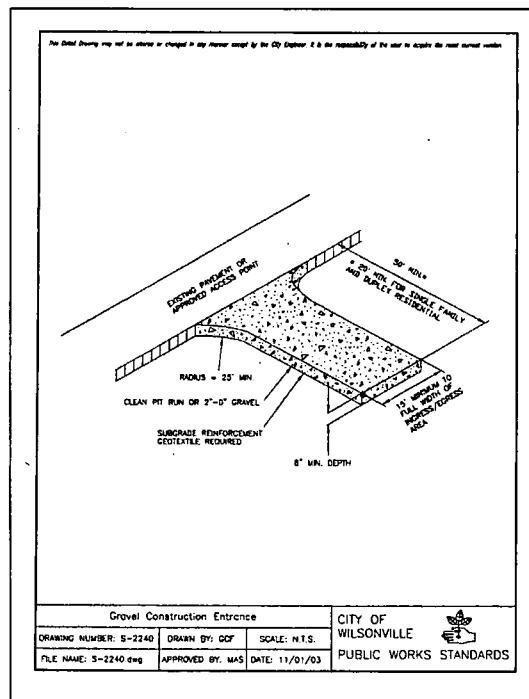

4 GRAVEL CONSTRUCTION ENTRANCE SECTION

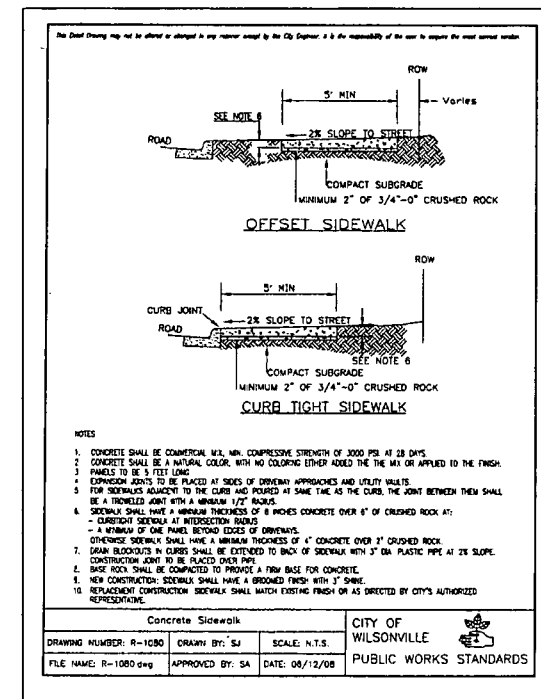

5 CURB TIGHT SIDEWALK SECTION



GreenWorks, P.C.
Landscape Architecture
Environmental Planner
24 4th St. N.W., Suite 300
Portland, Oregon 97209
Phone: 503.228.1740 Fax: 503.228.2503
Email: info@greenworks.com



project: **Engelman Park**

City of Wilsonville
13650 SW 97th
Wilsonville, OR 97150

submit: LAND USE SET
sheet title: **SITE DETAILS**

Date: 02-01-12
Revisions:

Drawn By: WS
Checked By: BJ
Job No: 110308
Approved: DE

L6.0

sheet no. X of X

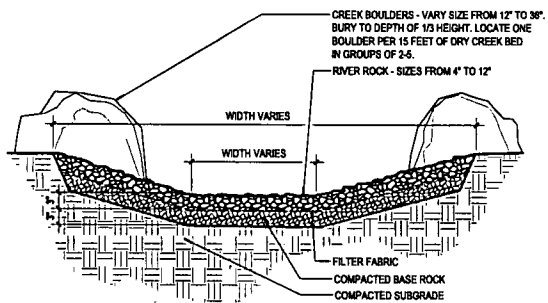

1 DRY CREEK BED

SECTION
0 3' 6' 12'

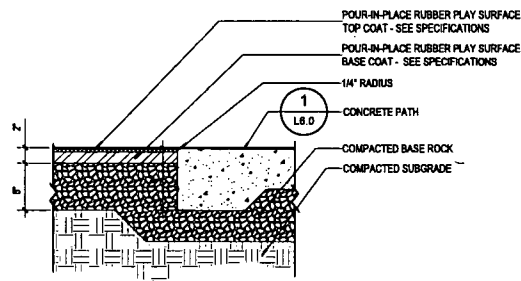

3 PLAYGROUND SURFACING

SECTION
0' 2' 4' 6'

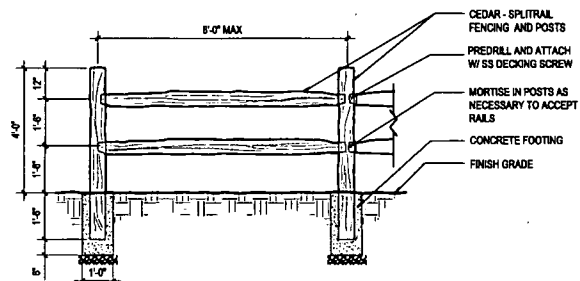

3 SPLIT RAIL FENCE

ELEVATION
0' 6' 12' 24'

NOTES:
1. ALL HARDWARE INCLUDING POSTS, BARS, FRAMES, LATCHES, HINGES, STRAPS, BOLTS, ETC. TO MATCH COLOR OF MESH FABRIC.

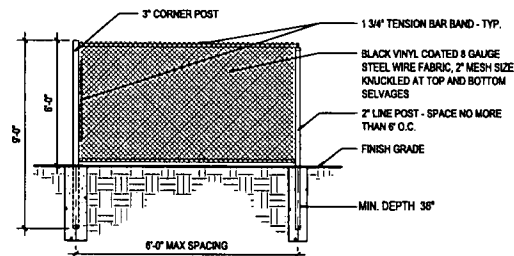

4 CHAIN LINK FENCE

ELEVATION
0 6' 12' 24'



project: **Engelman Park**
City of Wilsonville
33789 SW Tice Center Loop
Wilsonville, OR 97170

submit: **LAND USE SET**
sheet title: **SITE DETAILS**
Date: 02-01-12
Revisions:

Drawn By: WS
Checked By: BJ
Job No. 110308
Approved: DE

L6.1
sheet no. X of X

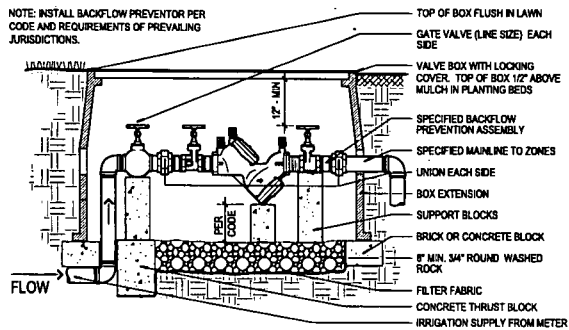

1 BACKFLOW PREVENTION ASSEMBLY

SECTION

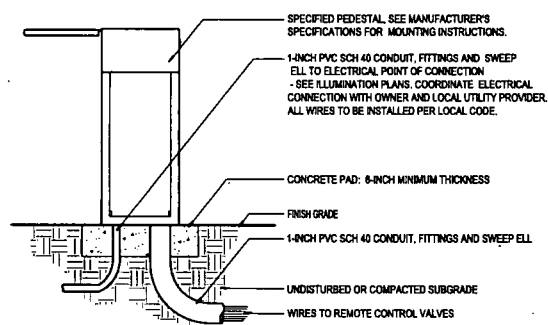

2 AUTOMATIC CONTROLLER

SECTION

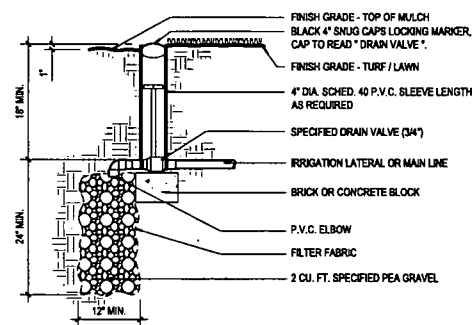

3 MANUAL DRAIN VALVE ASSEMBLY

NOT TO SCALE

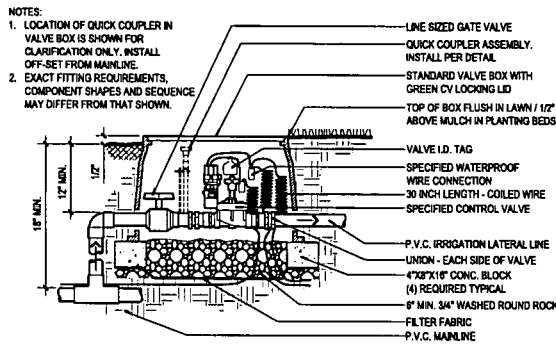

4 AUTOMATIC CONTROL VALVE ASSEMBLY

NOT TO SCALE

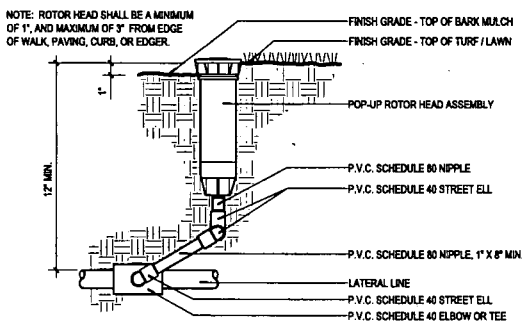

5 ROTOR HEAD - PVC SWING JOINT ASSEMBLY

NOT TO SCALE

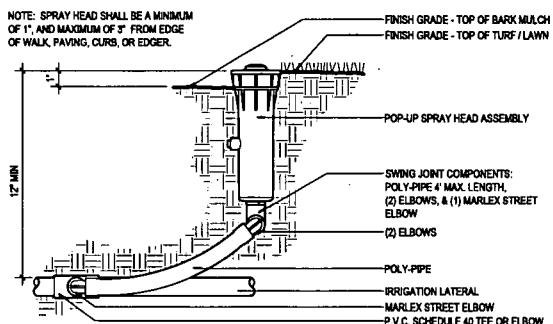

6 SPRAY HEAD - POLY SWING PIPE ASSEMBLY

NOT TO SCALE

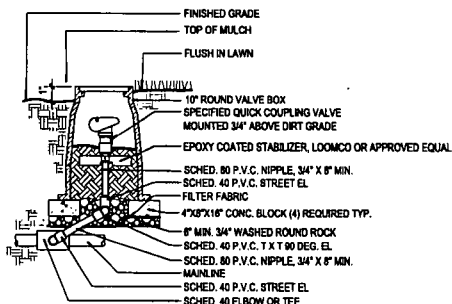

8 QUICK COUPLER VALVE ASSEMBLY

NOT TO SCALE

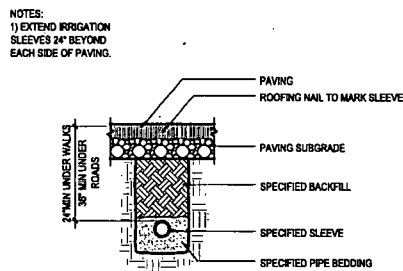

9 IRRIGATION SLEEVES UNDER PAVEMENT

NOT TO SCALE

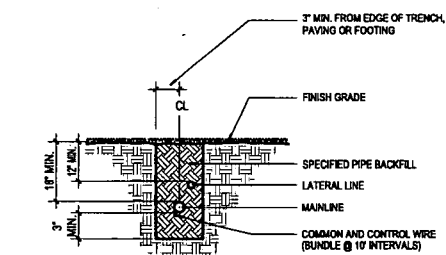

NOTE:

- CONTRACTOR SHALL REPAIR TRENCH SETTLEMENT AND RESTORE FINISH GRADES PRIOR TO SEEDING OR PLANTING OPERATIONS.

10 TRENCHING IN PLANTING AREA

NOT TO SCALE



GreenWorks, P.C.
Landscape Architecture
Environmental Design
24 90 3rd Avenue, Suite 400
Portland, Oregon 97201
Phone: 503.222.2700
Fax: 503.222.2700
Email: info@greenworks.com



1 sq. ft. of 10 seconds

Project: **Engelman Park**
City of Wilsonville
Wilsonville, OR 97150

Submitted: LAND USE SET
Sheet title: **IRRIGATION DETAILS**

Date: 02-01-12
Revisions:

Drawn By: WS
Checked By: BJ
Job No. 110308
Approved: DE

L6.2
sheet no. X of X

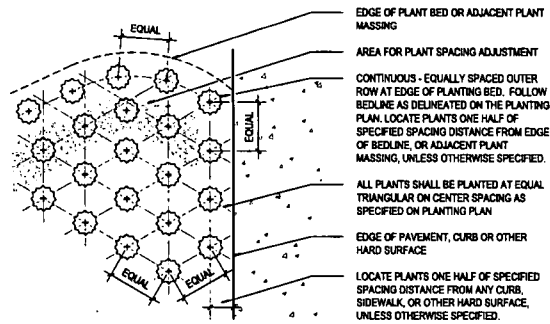

1 GROUNDCOVER PLANTING
PLAN NOT TO SCALE

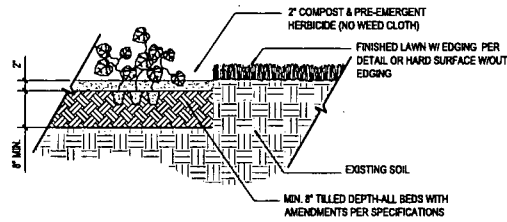

2 TYPICAL GROUNDCOVER PLANTING
SECTION 0' 3" 6" 12"

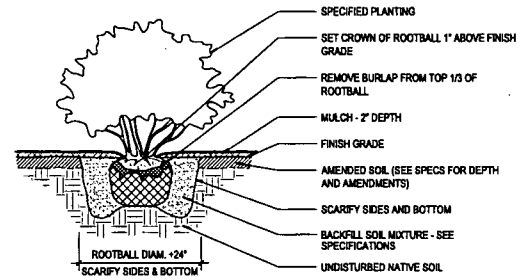

3 SHRUB PLANTING - B&B
SECTION 0' 6" 12" 24"

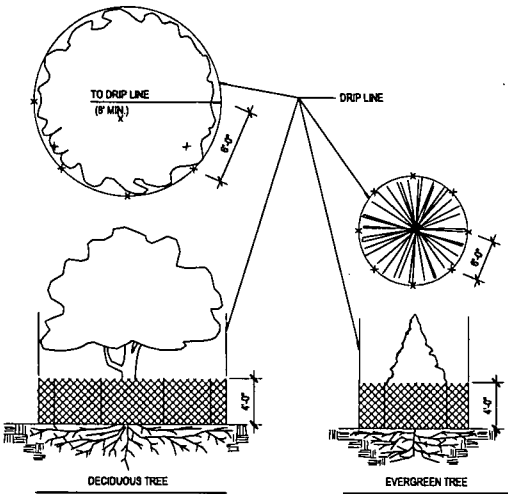

NO GRADING OR TRESPASSING INSIDE FENCE. FINAL GRADING SHALL NOT ALTER GRADE BY MORE THAN 6\"/>

CONSTRUCTION FENCING PER ARBORIST REPORT. SECURE TO STEEL POSTS PLACED 6\"/>

6 TREE PROTECTION FENCING
PLAN SECTION NOT TO SCALE

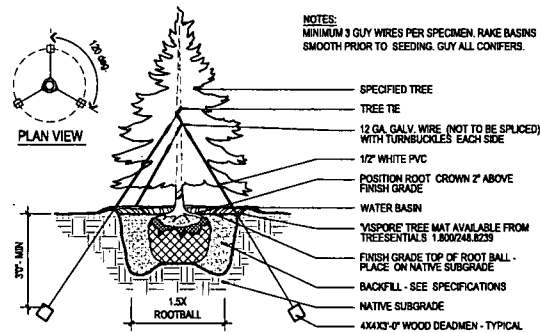

4 CONIFER TREE PLANTING - GUYING
SECTION 0' 6" 12" 24"

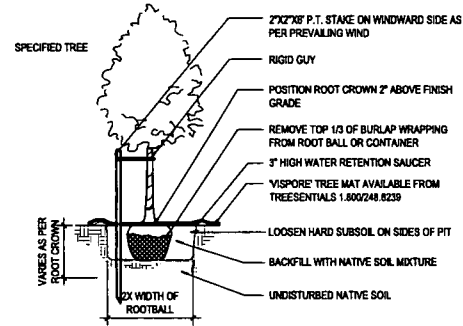

5 NATIVE DECIDUOUS TREE PLANTING
SECTION NOT TO SCALE



project: **Engelman Park**
City of Waconette
1000 W. Main Street, Suite 100
Waconette, OR 97170

submit: **LAND USE SET**
sheet title: **PLANTING DETAILS**

Date: 02-01-12
Revisions:
Drawn By: WS
Checked By: BJ
Job No. 110308
Approved: DE

L6.3
sheet no. X of X